

Distributed by
Raymarine

Any reference to Raytheon or RTN in this manual should be interpreted as Raymarine. The names Raytheon and RTN are owned by the Raytheon Company.

Autohelm

ST80 Active Speed and Depth Transducers

Installation Manual

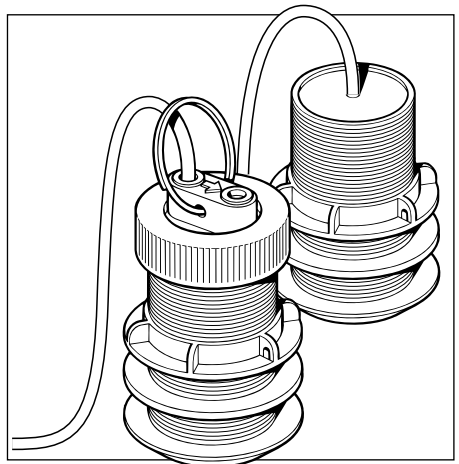



Package Contents

1. Transducer assembly
2. SeaTalk power cable
3. Screws (2)
4. Screws (2)
5. 3-way SeaTalk connector block
6. Installation manual
7. Warranty card

Contents

Chapter 1: Installation	3
1.1 Installing the Speed Sensor	3
General Points to Remember	3
1.2 Installing the Depth Sensor	4
General Points to remember	4
1.3 Installation of the Data Processing Unit	5
1.4 Connection to SeaTalk	5
1.5 Triducer Installation	7
Connecting the Triducer to SeaTalk	8
Data Processing Unit PCB Connections	8
Chapter 2: EMC and Servicing Guidelines	9
2.1 Important information	9
2.2 Installation	9
2.3 Check Before Going to Sea	10
2.4 Servicing and Safety	10
Chapter 3: Specification	11
3.1 Active Speed Transducer	11
3.2 Active Depth Transducer	11

Chapter 1: Installation

1.1 Installing the Speed Sensor

Please refer to the instructions provided in speed sensor package for complete installation details and recommendations.

These instructions should be read thoroughly before any attempt is made to install the speed sensor.

General Points to Remember

The speed sensor should be installed so that it is:

- Ahead of the propellers.
- At least 150mm (6in) from the keel and ideally forward of the keel.

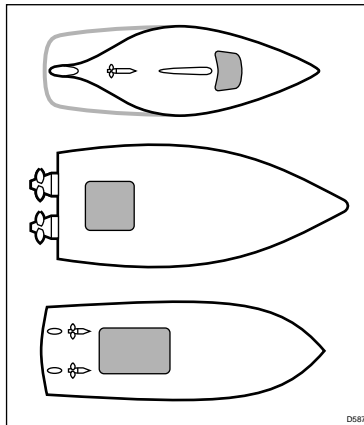

- Near the centre line of the vessel.
- Clear of all through hull fittings and projections.

There should also be sufficient space above the sensor to allow the paddle wheel assembly to be removed.

Alternative active transducers are available from your Autohelm dealer. The range includes: bronze through hull speed and a transom mount triducer.

1.2 Installing the Depth Sensor

Procedures for fitting the sensor to the hull of your vessel are supplied in the sensor package. Please read these instructions thoroughly before attempting to install the unit.

General Points to remember

A warning label covers the face of the depth sensor. This label should be removed before use and the face of the sensor “wetted” with a household detergent.

The sensor should be installed so that it is:

- near the centreline of the vessel (within 10° of the vertical)

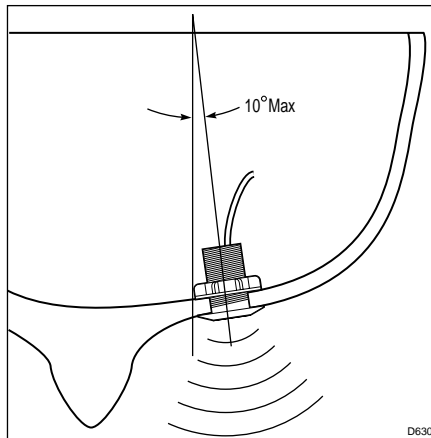

- ahead of the propellers and forward of the keel
- clear of all other through hull fittings or projections

1.3 Installation of the Data Processing Unit

The cables from the data processor are 2m (6ft) in length. Therefore, a 3-way SeaTalk connector block must be sited within 4m (12ft) of the transducer.

Use the 19mm (3/4in) self-tapping screws to mount the processor vertically or horizontally to a springer or beam.

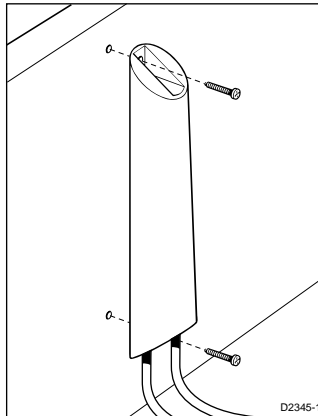

Note: Position both the data processor and the SeaTalk connector block clear of any bilge water.

1.4 Connection to SeaTalk

Plug the free end of the data processor cable into any 3-way connector block.

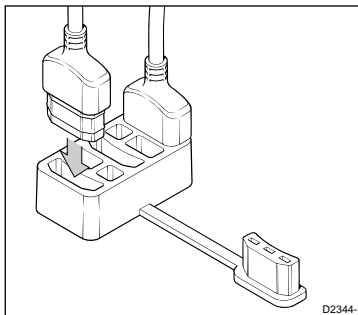

The following illustration shows a typical SeaTalk system and the method of inter-unit connection.

- (1) Depth sensor
- (2) Data processing unit
- (3) SeaTalk 3-way junction box
- (4) Power cable
- (5) ST80 Masterview display head

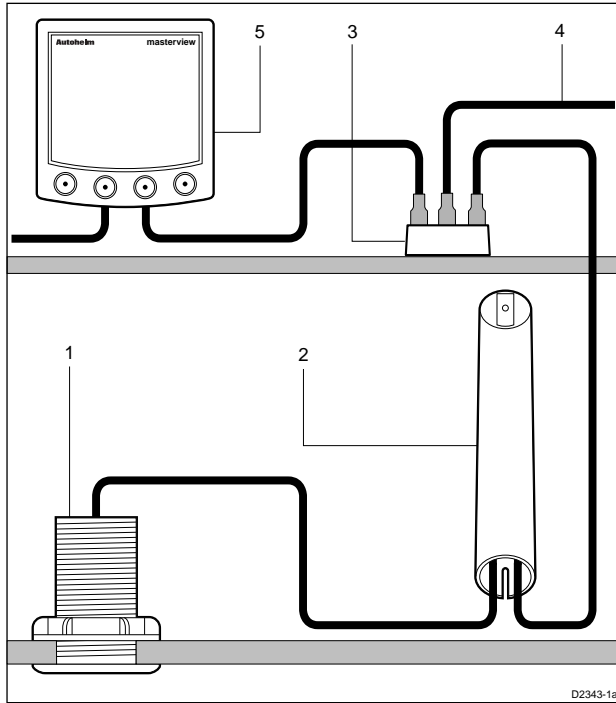

- (1) Speed sensor
- (2) Data processing unit
- (3) SeaTalk 3-Way connector block
- (4) ST80 Display head

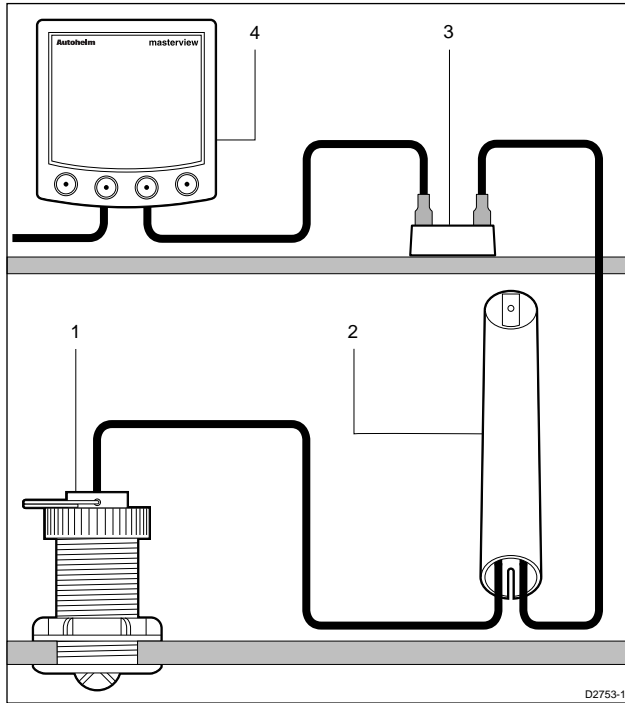

1.5 Triducer Installation

There are two triducers available, one for transom mounting and a second, bronze unit, for through hull mounting. Triducers provide speed, depth and temperature information and comprise of two data processors and a triducer housing.

Please refer to the instructions provided in the triducer package for details on how to install the triducer housing.

Connecting the Triducer to SeaTalk

The data processors should be connected to SeaTalk as follows.

- (1) ST80 Display head
- (2) SeaTalk 3-way connector block
- (3) Depth data processor
- (4) Speed data processor
- (5) Depth cable to Triducer
- (6) Speed cable to Triducer

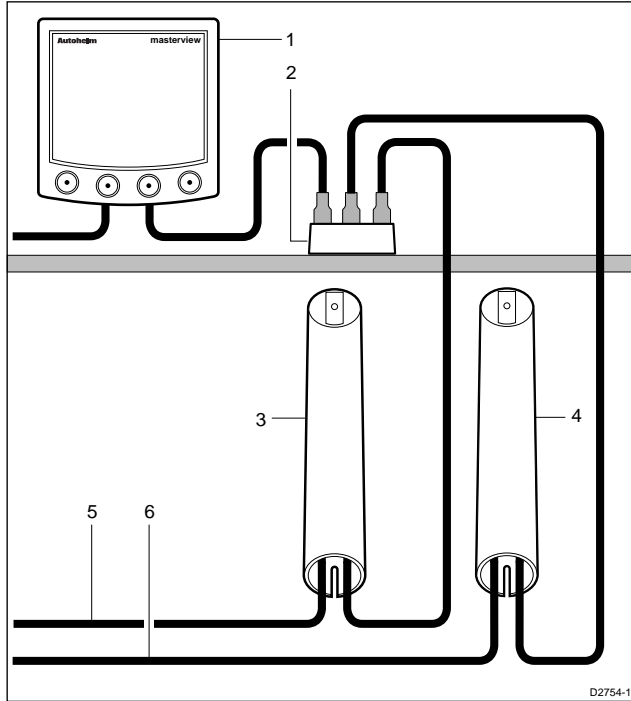

Data Processing Unit PCB Connections

If it is not possible to install the transducers without disconnecting the sensor from the data processor, make sure that the wires are reconnected to the correct terminals as shown.

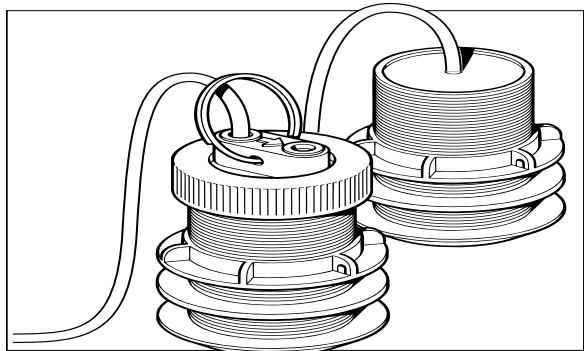

Chapter 2: EMC and Servicing Guidelines

2.1 Important information

All Autohelm equipment and accessories are designed to the best industry standards for use in the leisure marine environment.

Their design and manufacture conforms to the appropriate Electromagnetic Compatibility (EMC) standards, but good installation is required to ensure that performance is not compromised. Although every effort has been taken to ensure that they will perform under all conditions, it is important to understand what factors could affect the operation of the product.

2.2 Installation

To avoid the risk of operating problems, all Autohelm equipment and cables connected to it should be:

- At least 1m (3 feet) from any equipment transmitting or cables carrying radio signals, e.g., VHF radios, cables and antennas. In the case of SSB radios, the distance should be increased to 2m (7ft).
- More than 2m (6ft) from the path of a radar beam. A radar beam can normally be assumed to spread 20 degrees above and below the radiating element.
- The equipment should be supplied from a different battery than the one used for engine start. Voltage drops below 10V in the power supply to our products can cause the equipment to reset. This will not damage the equipment, but will cause the loss of some information and can change the operating mode.
- Genuine Autohelm cables should be used at all times. Cutting and rejoining these cables can compromise EMC performance and so should be avoided unless doing so is detailed in the installation manual.
- If a suppression ferrite is attached to a cable, this ferrite should not be removed. If the ferrite has to be removed during installation it must be reassembled in the same position.

2.3 Check Before Going to Sea

- Always check the installation before going to sea to make sure that it is not affected by radio transmissions, engine starting etc..
- In some installations, it may not be possible to prevent the equipment from being affected by external influences. In general this will not damage the equipment but can lead to it resetting, or momentarily may result in faulty operation.

2.4 Servicing and Safety

- Autohelm equipment should be serviced only by authorised Autohelm service engineers. They will ensure that service procedures and replacement parts used will not affect performance. There are no user serviceable parts in any Autohelm product.
- Some products generate high voltages, and so never handle the cables/connectors when power is being supplied to the equipment.
- Always report any EMC related problem to your nearest Autohelm dealer. We will use any such information to improve our quality standards.

Chapter 3: Specification

3.1 Active Speed Transducer

Cable length:	2m (6ft) each cable
Speed range:	0 to 60 knots
Temperature range:	-10 to +40°C (14 to 104°F)
Power supply:	10 to 16V
Current consumption:	25mA

3.2 Active Depth Transducer

Cable length:	2m (6ft) each cable
Depth range:	1.5 to 600ft (200ft at 25 knots) and 600ft at 5 knots.
Power consumption:	50 mA
Power supply:	10 to 16V
Transmitted power:	50W RMS

()

Raymarine Ltd.
Anchorage Park, Portsmouth,
P03 5TD, England.
Telephone: +44 (0) 2392 693611
Fax: +44 (0) 2392 694642

Autohelm
